

# POWER RELAY

# 1 POLE—16 A (HEAVY POWER CONTROL) VSB SERIES

RoHS compliant

## ■ FEATURES

- All or nothing relay
- UL, CSA, VDE, SEV, FIMKO, SEMKO, ÖVE, BSI recognized
- Working class: C
- Type of service: continuous duty
- Heavy duty 16 A miniature power relay
- UL Class B (130°C) insulation
- High isolation in small package
  - Insulation distance: 8 mm
  - Dielectric strength: 5,000 VAC (between coil and contacts)
  - Surge strength: 10,000 V
- Low power consumption and high sensitivity type available VSB-S)
- Plastic sealed (with tape) type available
- RoHS compliant since date code:0523  
Please see page 6 for more information



## ■ ORDERING INFORMATION

VSB - 12 S T B

[Example] (a) (\*) (b) (c) (d) (e)

(a)	Series Name	VSB: VSB Series
(b)	Nominal Voltage	Refer to the COIL DATA CHART
(c)	Coil Type	Nil : Standard type (700 to 750 mW) S : High sensitivity type (530 mW)
(d)	Contact Arrangement	M : 1 form A (SPST-NO) T : 1 form C (SPDT)
(e)	Enclosure	B : Flux free type C : Plastic sealed type (with tape)

Note: Actual marking omits the hyphen (-) of (\*)

# VSB SERIES

## ■ COIL DATA CHART

	MODEL	Nominal voltage	Coil resistance (±10%)	Must operate voltage*	Must release voltage*	Nominal power
Standard Type	VSB- 3 ( ) ( )	3 VDC	12.5 Ω	2.1 VDC	0.3 VDC	720 mW
	VSB- 5 ( ) ( )	5 VDC	36 Ω	3.5 VDC	0.5 VDC	700 mW
	VSB- 6 ( ) ( )	6 VDC	50 Ω	4.2 VDC	0.6 VDC	720 mW
	VSB- 9 ( ) ( )	9 VDC	115 Ω	6.3 VDC	0.9 VDC	700 mW
	VSB- 12 ( ) ( )	12 VDC	200 Ω	8.4 VDC	1.2 VDC	720 mW
	VSB- 14 ( ) ( )	14 VDC	280 Ω	9.8 VDC	1.4 VDC	700 mW
	VSB- 18 ( ) ( )	18 VDC	460 Ω	12.6 VDC	1.8 VDC	700 mW
	VSB- 24 ( ) ( )	24 VDC	820 Ω	16.8 VDC	2.4 VDC	700 mW
	VSB- 36 ( ) ( )	36 VDC	1,850 Ω	25.2 VDC	3.6 VDC	700 mW
	VSB- 48 ( ) ( )	48 VDC	3,300 Ω	33.6 VDC	4.8 VDC	700 mW
	VSB- 60 ( ) ( )	60 VDC	5,100 Ω	42.0 VDC	6.0 VDC	700 mW
	VSB-100 ( ) ( )	100 VDC	13,400 Ω	70.0 VDC	10.0 VDC	750 mW
High Sensitivity Type	VSB- 3S ( ) ( )	3 VDC	17 Ω	2.1 VDC	0.3 VDC	530 mW
	VSB- 5S ( ) ( )	5 VDC	47 Ω	3.5 VDC	0.5 VDC	530 mW
	VSB- 6S ( ) ( )	6 VDC	68 Ω	4.2 VDC	0.6 VDC	530 mW
	VSB- 9S ( ) ( )	9 VDC	155 Ω	6.3 VDC	0.9 VDC	530 mW
	VSB- 12S ( ) ( )	12 VDC	270 Ω	8.4 VDC	1.2 VDC	530 mW
	VSB- 14S ( ) ( )	14 VDC	370 Ω	9.8 VDC	1.4 VDC	530 mW
	VSB- 18S ( ) ( )	18 VDC	610 Ω	12.6 VDC	1.8 VDC	530 mW
	VSB- 24S ( ) ( )	24 VDC	1,100 Ω	16.8 VDC	2.4 VDC	530 mW
	VSB- 36S ( ) ( )	36 VDC	2,450 Ω	25.2 VDC	3.6 VDC	530 mW
	VSB- 48S ( ) ( )	48 VDC	4,400 Ω	33.6 VDC	4.8 VDC	530 mW
	VSB- 60S ( ) ( )	60 VDC	6,800 Ω	42.0 VDC	6.0 VDC	530 mW
	VSB-100S ( ) ( )	100 VDC	18,560 Ω	70.0 VDC	10.0 VDC	530 mW

Note: All values in the table are measured at 20°C.

\*: Specified values are subject to pulse wave voltage

## ■ SPECIFICATIONS

Item		Standard Type VSB- ( )	High Sensitive type VSB-( )-S
Contact	Arrangement	1 form A (SPST- NO) or 1 form C (SPDT)	
	Material	Silver alloy (AgSnO)	
	Configuration	Single	
	Resistance (initial)	Maximum 100 mΩ at 1 A, 6 VDC	
	Rating	16 A, 250 VAC / 30 VDC	
	Maximum Carrying Current*1	16 A	
	Maximum Switching Rating	4,000 VA / 480W	
	Maximum Switching Voltage	250 VAC / 150VDC	
	Maximum Switching Current	16A	
	Maximum Switching Load*2	100 mA 5 VDC	
Coil	Nominal Power (at 20°C)	700 to 750 mW	530 mW
	Operate Power (at 20°C)	350 to 370 mW	260 mW
	Operating Temperature	-40°C to +65°C (no frost)	-40°C to +75°C (no frost)
Time Value	Operate (at nominal voltage)	Maximum 15ms	
	Release (at nominal voltage)	Maximum 10ms	
Life	Mechanical	2 x 10 <sup>7</sup> operations minimum	
	Electrical	1 x 10 <sup>5</sup> operations minimum (contact rating)	
Other	Vibration Resistance	Misoperation	10 to 55 Hz, at double amplitude of 1.5 mm
		Endurance	10 to 55Hz, at double amplitude of 1.5 mm
	Shock Resistance	Misoperation	Min. 100m/s <sup>2</sup> (11±1ms)
		Endurance	Min. 1,000m/s <sup>2</sup> (6±1ms)
	Weight	Approximately 18g	

\*1 Need to consider the head from PCB when max. current is more than 10A.

\*2 Minimum switching loads mentioned above are reference values. Please perform the confirmation test with the actual load before production since reference values may vary according to switching frequencies, environmental conditions and expected reliability levels.

## ■ INSULATION

Item		VSB	Note
Resistance (initial)		Minimum 1,000 MΩ	at 500 VDC
Dielectric Strength	open contacts	1,000 VAC (50/60 Hz) 1 min.	
	coil and contacts	5,000 VAC (50/60 Hz) 1 min.	
Surge Voltage (coil and contact)		10,000 V	1.2 x 50μs standard wave

## ■ SAFETY STANDARDS

Type	Compliance	Contact rating
UL	UL 508, 873	Flammability: UL 94-V0 (plastics)
	E56140	16A, 250VAC/30VDC (resistive) 1/3 HP, 250VAC/125VAC
CSA	C22.2 No. 14 LR 35579	Pilot duty: C150
VDE	0435, 0631, 0700, 0860	

Complies with SEV, SEMKO, FIMKO, ÖVE, BSI

## CHARACTERISTIC DATA

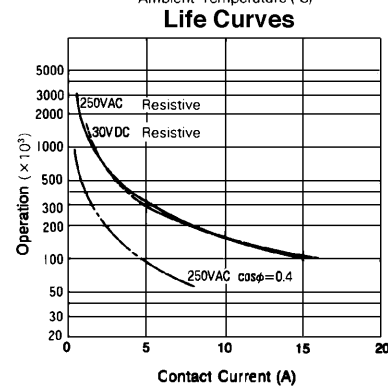
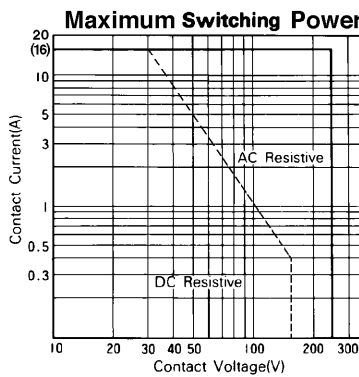
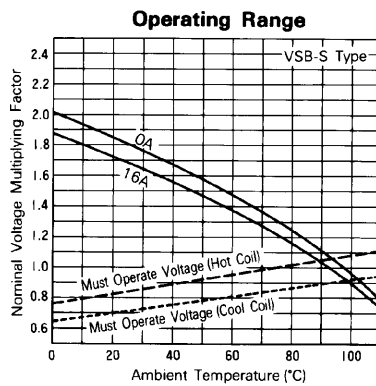
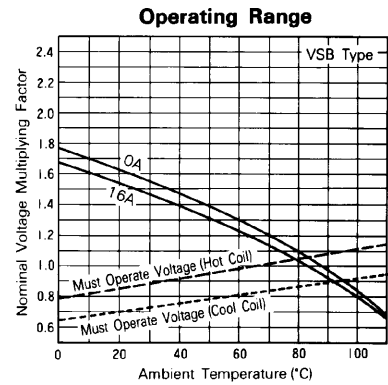
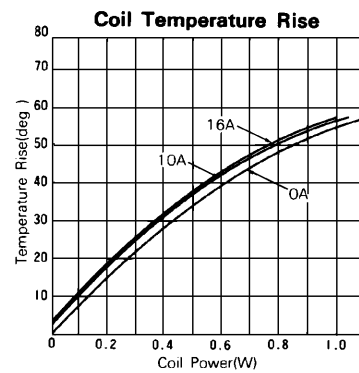
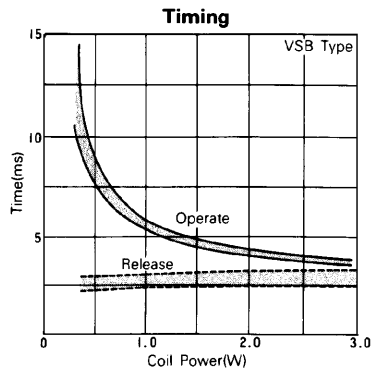

## REFERENCE DATA

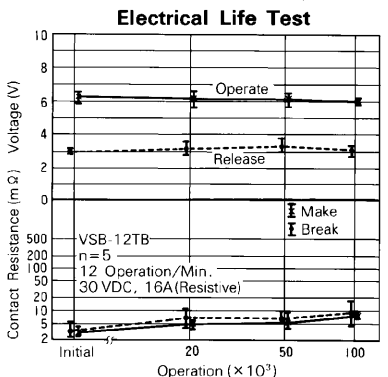
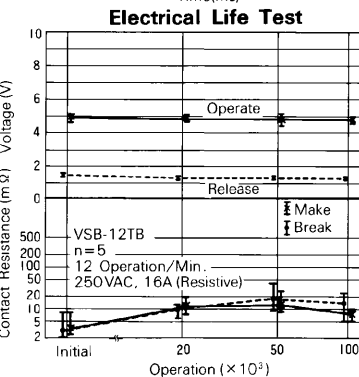
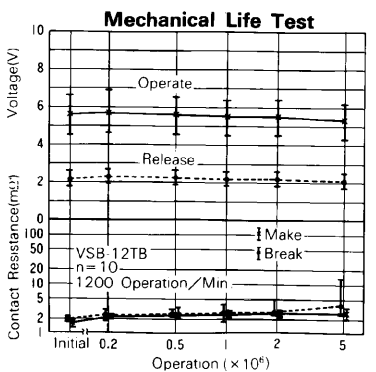
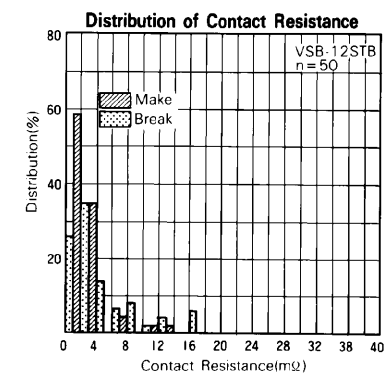
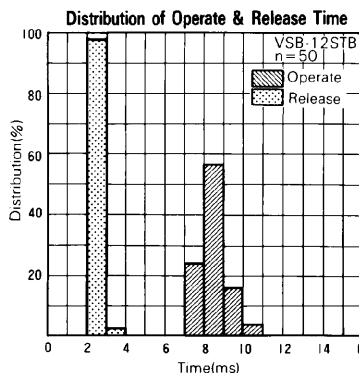
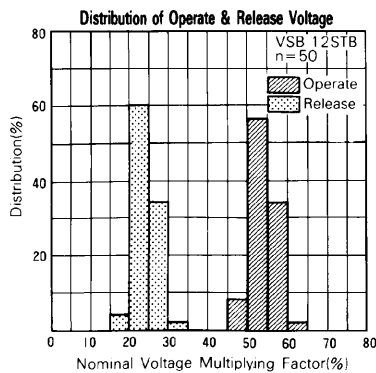

# VSB SERIES

## ■ DIMENSIONS

### ● Dimensions

#### VSB-M type

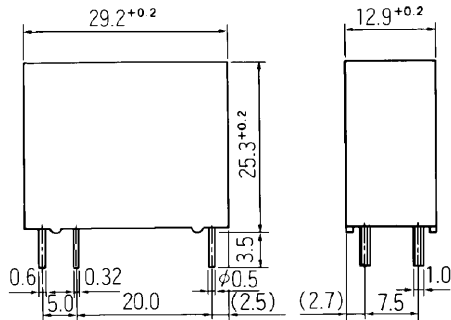

### ● PC board mounting hole layout (BOTTOM VIEW)

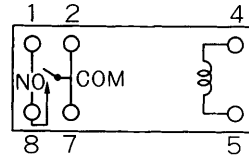

### ● Schematics (BOTTOM VIEW)

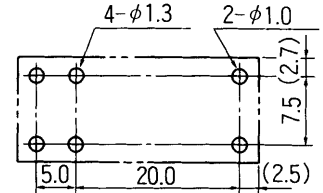

#### VSB type

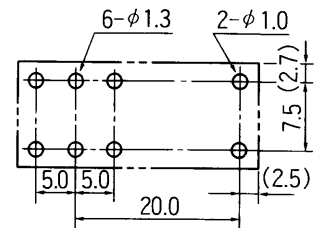
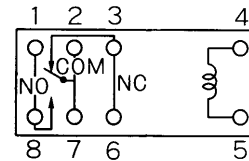
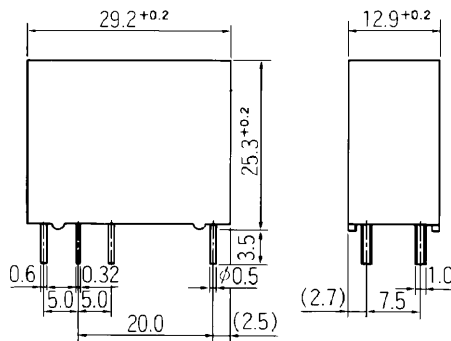

#### VSB-MC type (Plastic sealed type with tape)

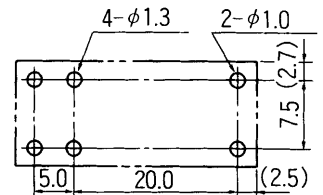
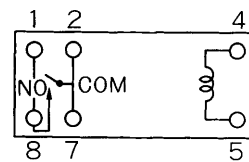
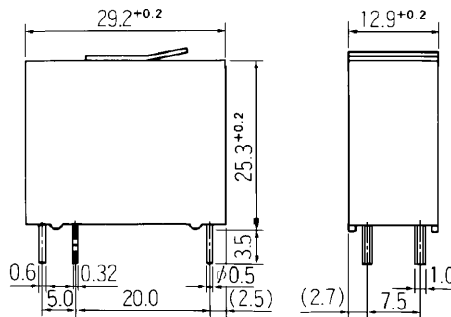

#### VSB-C type (Plastic sealed type with tape)

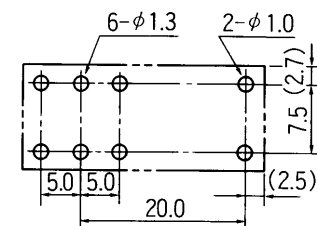
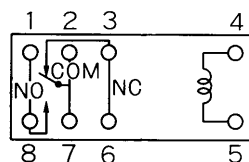
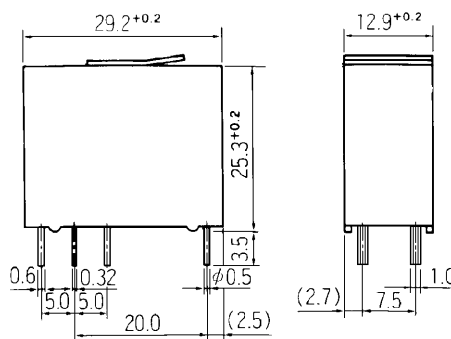

Unit: mm

## RoHS Compliance and Lead Free Relay Information

### 1. General Information

- Relays produced after the specific date code that is indicated on each data sheet are lead-free now. All of our signal and power relays are lead-free. Please refer to Lead-Free Status Info. (<http://www.fcai.fujitsu.com/pdf/LeadFreeLetter.pdf>)
- Lead free solder paste currently used in relays is Sn-3.0Ag-0.5Cu. From February 2005 forward Sn-3.0Cu-Ni will be used for FTRB3 and FTR-B4 series relays.
- All signal and power relays also comply with RoHS. Please refer to individual data sheets. Relays that are RoHS compliant do not contain the 6 hazardous materials that are restricted by RoHS directive (lead, mercury, cadmium, chromium IV, PBB, PBDE).
- It has been verified that using lead-free relays in leaded assembly process will not cause any problems (compatible).
- "LF" is marked on each outer and inner carton. (No marking on individual relays).
- To avoid leaded relays (for lead-free sample, etc.) please consult with area sales office.

We will ship leaded relays as long as the leaded relay inventory exists.

### 2. Recommended Lead Free Solder Profile

- Recommended solder paste Sn-3.0Ag-0.5Cu and Sn-3.0 Cu-Ni (only FTR-B3 and FTR-B4 from February 2005)

#### Reflow Solder condi-

**Flow Solder condition:**

Pre-heating: maximum 120°C  
Soldering: dip within 5 sec. at  
260°C solder bath

**Solder by Soldering Iron:**

Soldering Iron  
Temperature: maximum 360°C  
Duration: maximum 3 sec.

**We highly recommend that you confirm your actual solder conditions**

### 3. Moisture Sensitivity

- Moisture Sensitivity Level standard is not applicable to electromechanical relays.

### 4. Tin Whisker

- SnAgCu solder is known as low risk of tin whisker. No considerable length whisker was found by our in-house test.

### 5. Solid State Relays

- Each lead terminal will be changed from solder plating to Sn plating and Nickel plating. A layer of Nickel plating is between the terminal and the Sn plating to avoid whisker.

## Fujitsu Components International Headquarter Offices

### Japan

Fujitsu Component Limited  
Gotanda-Chuo Building  
3-5, Higashigotanda 2-chome, Shinagawa-ku  
Tokyo 141, Japan  
Tel: (81-3) 5449-7010  
Fax: (81-3) 5449-2626  
Email: [promothq@ft.ed.fujitsu.com](mailto:promothq@ft.ed.fujitsu.com)  
Web: [www.fcl.fujitsu.com](http://www.fcl.fujitsu.com)

### North and South America

Fujitsu Components America, Inc.  
250 E. Caribbean Drive  
Sunnyvale, CA 94089 U.S.A.  
Tel: (1-408) 745-4900  
Fax: (1-408) 745-4970  
Email: [components@us.fujitsu.com](mailto:components@us.fujitsu.com)  
Web: <http://www.fujitsu.com/us/services/edevice/components/>

### Europe

Fujitsu Components Europe B.V.  
Diamantlaan 25  
2132 WV Hoofddorp  
Netherlands  
Tel: (31-23) 5560910  
Fax: (31-23) 5560950  
Email: [info@fceu.fujitsu.com](mailto:info@fceu.fujitsu.com)  
Web: [emea.fujitsu.com/components/](http://emea.fujitsu.com/components/)

### Asia Pacific

Fujitsu Components Asia Ltd.  
102E Pasir Panjang Road  
#01-01 Citilink Warehouse Complex  
Singapore 118529  
Tel: (65) 6375-8560  
Fax: (65) 6273-3021  
Email: [fcac@fcal.fujitsu.com](mailto:fcac@fcal.fujitsu.com)  
Web: <http://www.fujitsu.com/sg/services/micro/components/>

©2007 Fujitsu Components America, Inc. All rights reserved. All trademarks or registered trademarks are the property of their respective owners.

Fujitsu Components America or its affiliates do not warrant that the content of datasheet is error free. In a continuing effort to improve our products Fujitsu Components America, Inc. or its affiliates reserve the right to change specifications/datasheets without prior notice.  
Rev. November 30, 2007